

WSD WG06 ITIL/ITSM procesy a nástroje 2010

Orchestrácia a automatizácia ITIL/ITSM procesov



14.10.2010 Hotel Matyšák, Bratislava

Orchestrácia nástrojov riadenia IT

itSMF 2010

Oblasti riadenia IT

- ServiceDesk
- Identity Management
- Infrastructure Management
- Project Management
- IT Asset Management
- Security Information Management

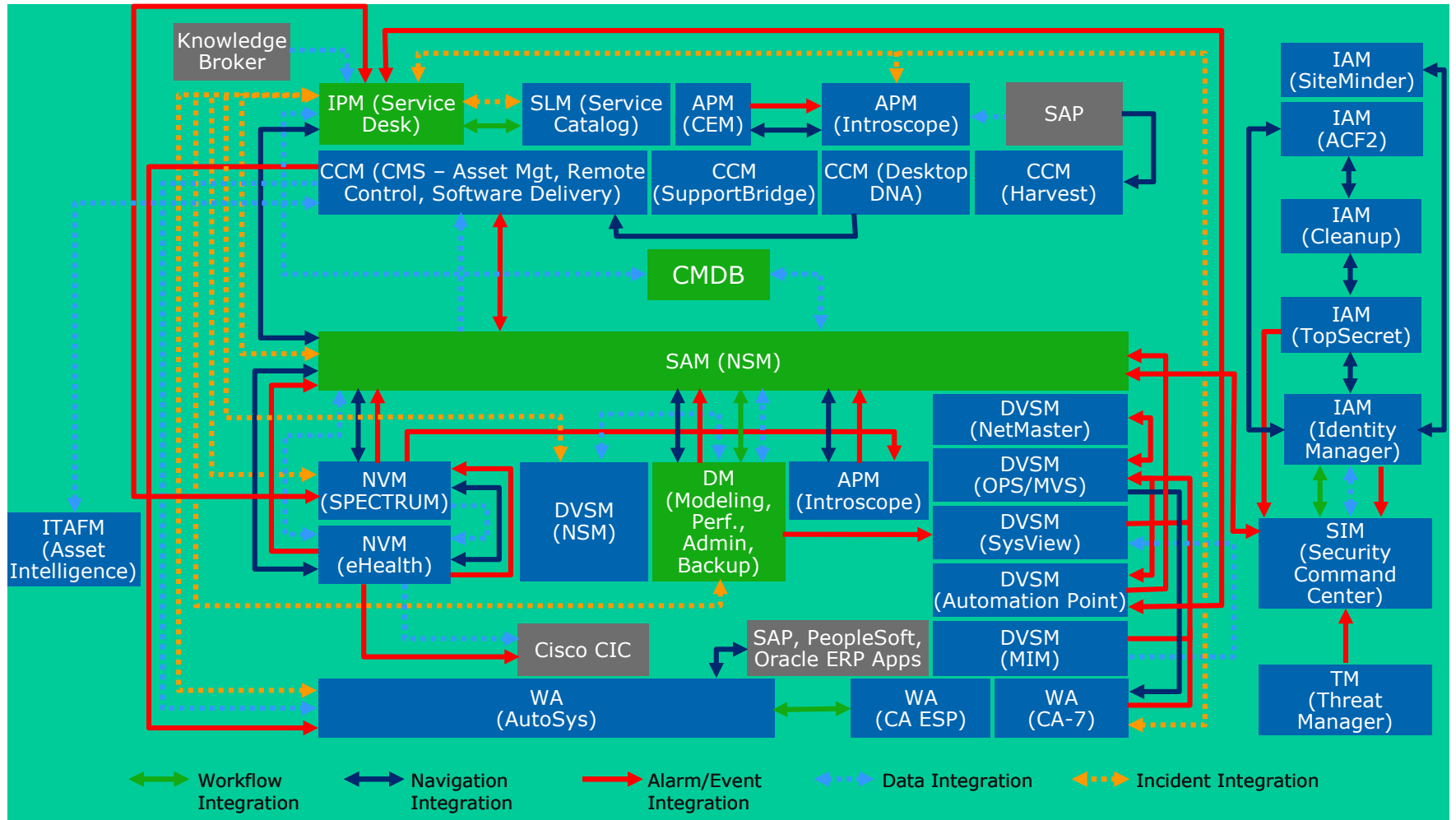

Orchestrácia s nástrojom

- Vizualizácia procesov, prehľad
- Pomerne rozsiahle možnosti
- Schopnosť udržiavania objednávateľom
- Vyššia cena
- Dlhší čas implementácie
- Podporované výrobcom

CA IT Process Automation Manager

- Vizualizácia procesov, prehľad
- Pomerne rozsiahle možnosti
- Schopnosť udržiavania objednávateľom
- Nulová obstarávacia cena, všetky konektory v balíku
- Podporované IT nástroje
- Dlhší čas implementácie
- Komplikovaný prechod od použitia „hocičoho“

CA IT PAM príklad konektorov

Service Desk	Network Management	System Management	Operating Systems	Workload Managers
<ul style="list-style-type: none"> ➤ CA Service Desk ➤ HP Service Center ➤ BMC Remedy 	<ul style="list-style-type: none"> ➤ CA Spectrum ➤ Ciscoworks ➤ HP OpenView NNM ➤ IBM Netcool ➤ IBM Tivoli 	<ul style="list-style-type: none"> ➤ Microsoft Operations Manager (MS MOM) ➤ Tivoli Enterprise Console ➤ HP OpenView Operations ➤ CA Data Center Automation Manager 	<ul style="list-style-type: none"> ➤ Microsoft Windows ➤ Unix ➤ Linux ➤ VMWare VirtualCenter 	<ul style="list-style-type: none"> ➤ CA Autosys ➤ CA D-Series ➤ BMC Control-M

Orchestrácia nástrojov IT

- Proces nasadenia
 - Analýza
 - Návrh (automatizované, manuálne procesy, rozhrania, vstup, výstup, podprocesy, podmienky – hodnoty, čas ..)
 - Implementácia
 - Podpora
- Objekty orchestrácie
 - Procesy
 - Objekty
 - GUI

Architektúra a bezpečnosť

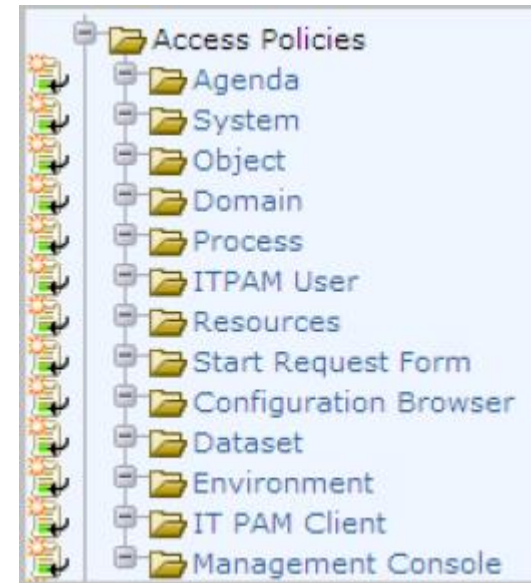
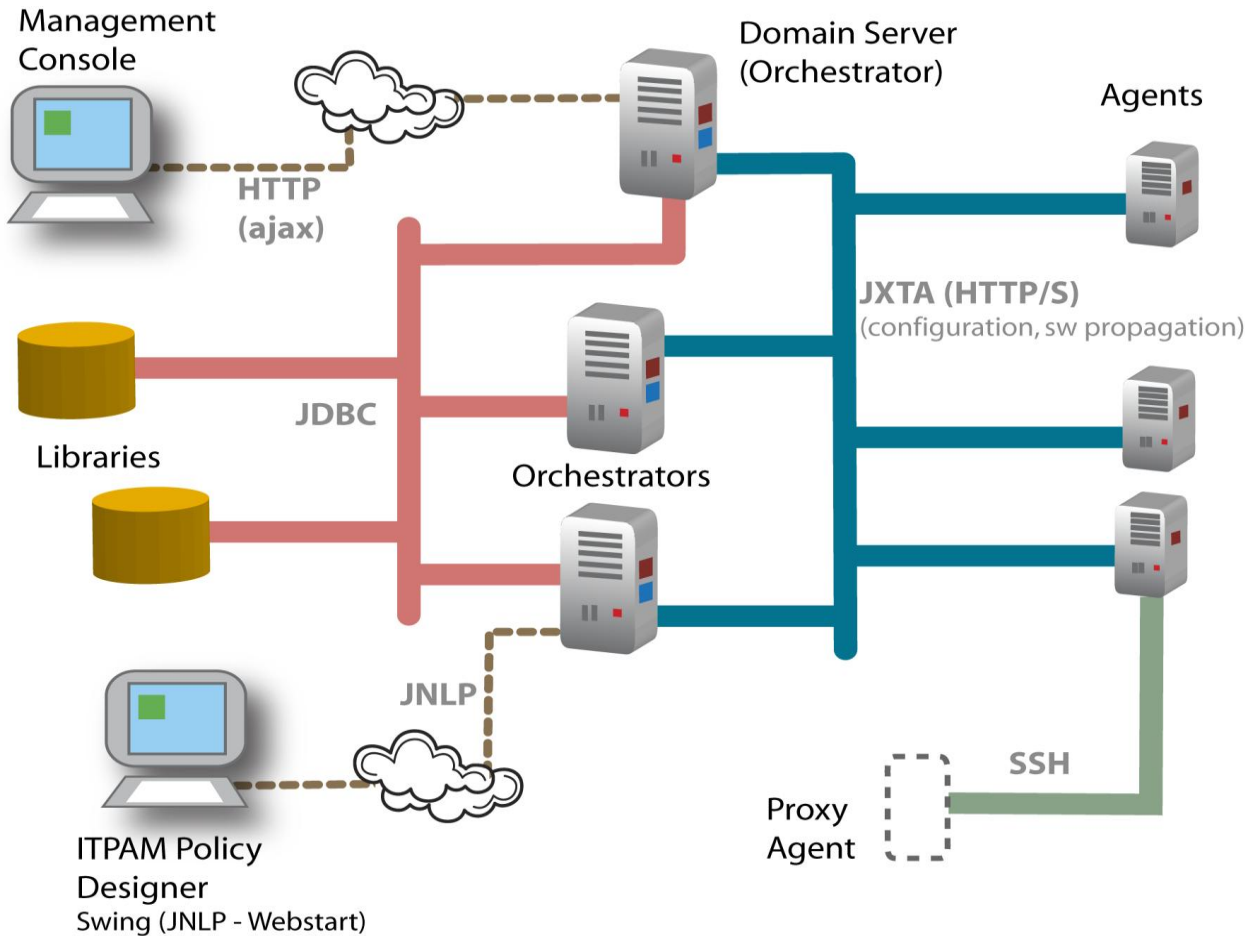

Architektúra agentov

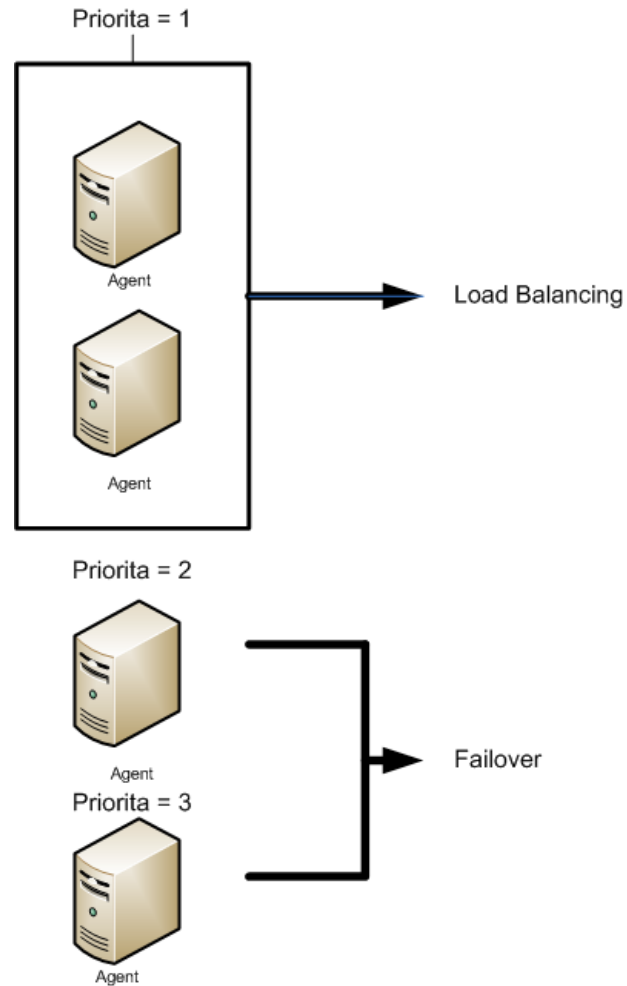

Procesy

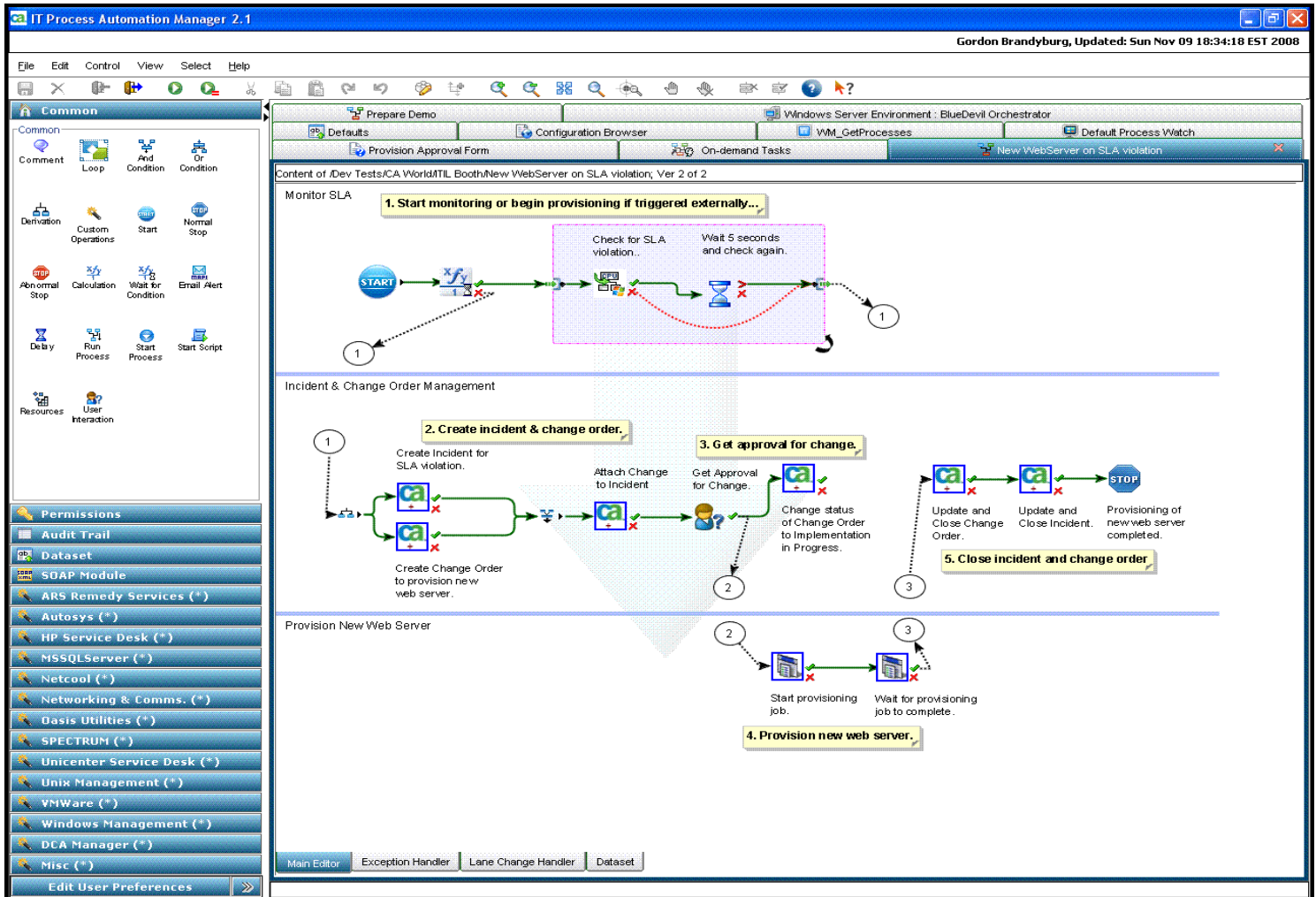

IT PAM

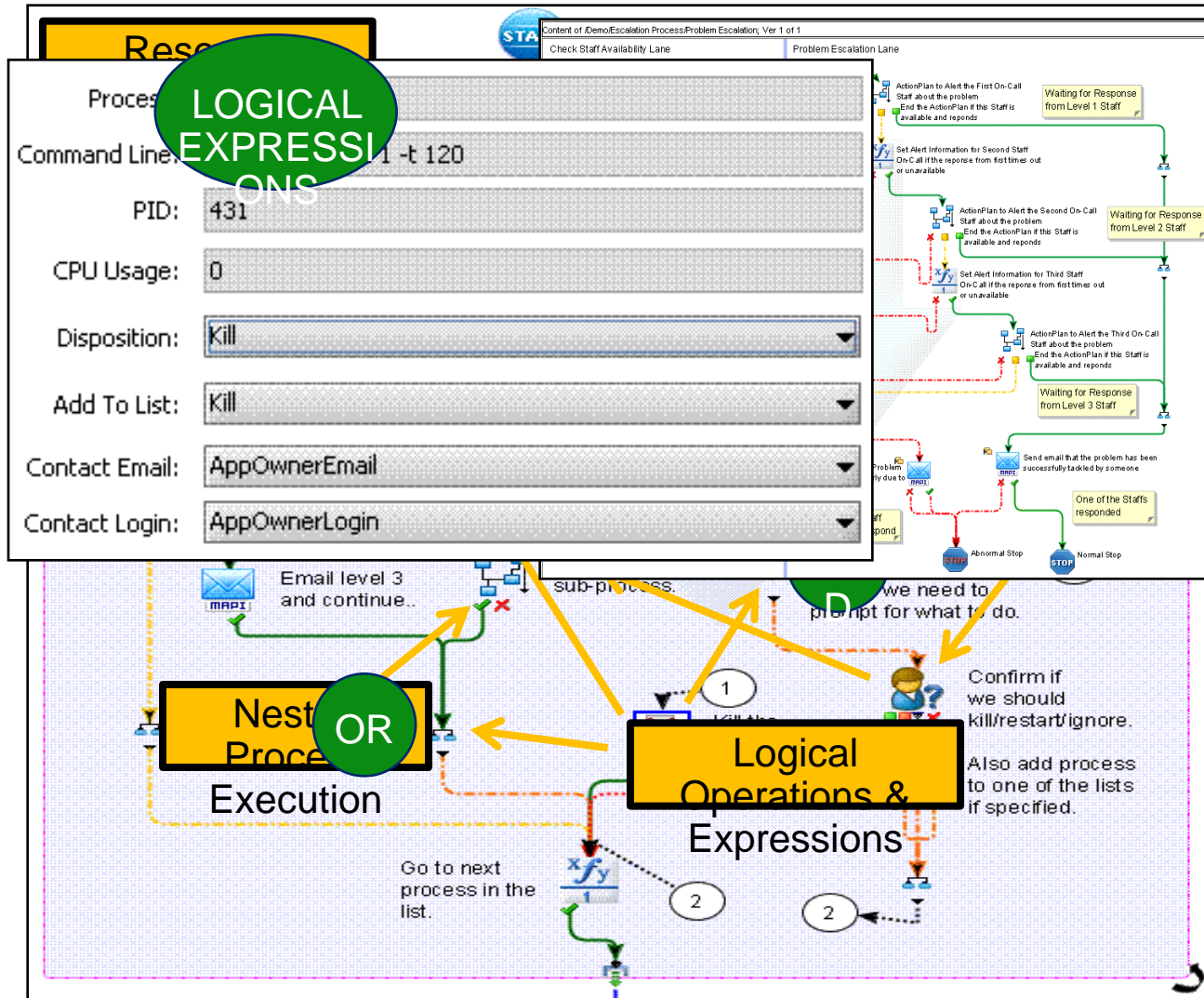

IT PAM

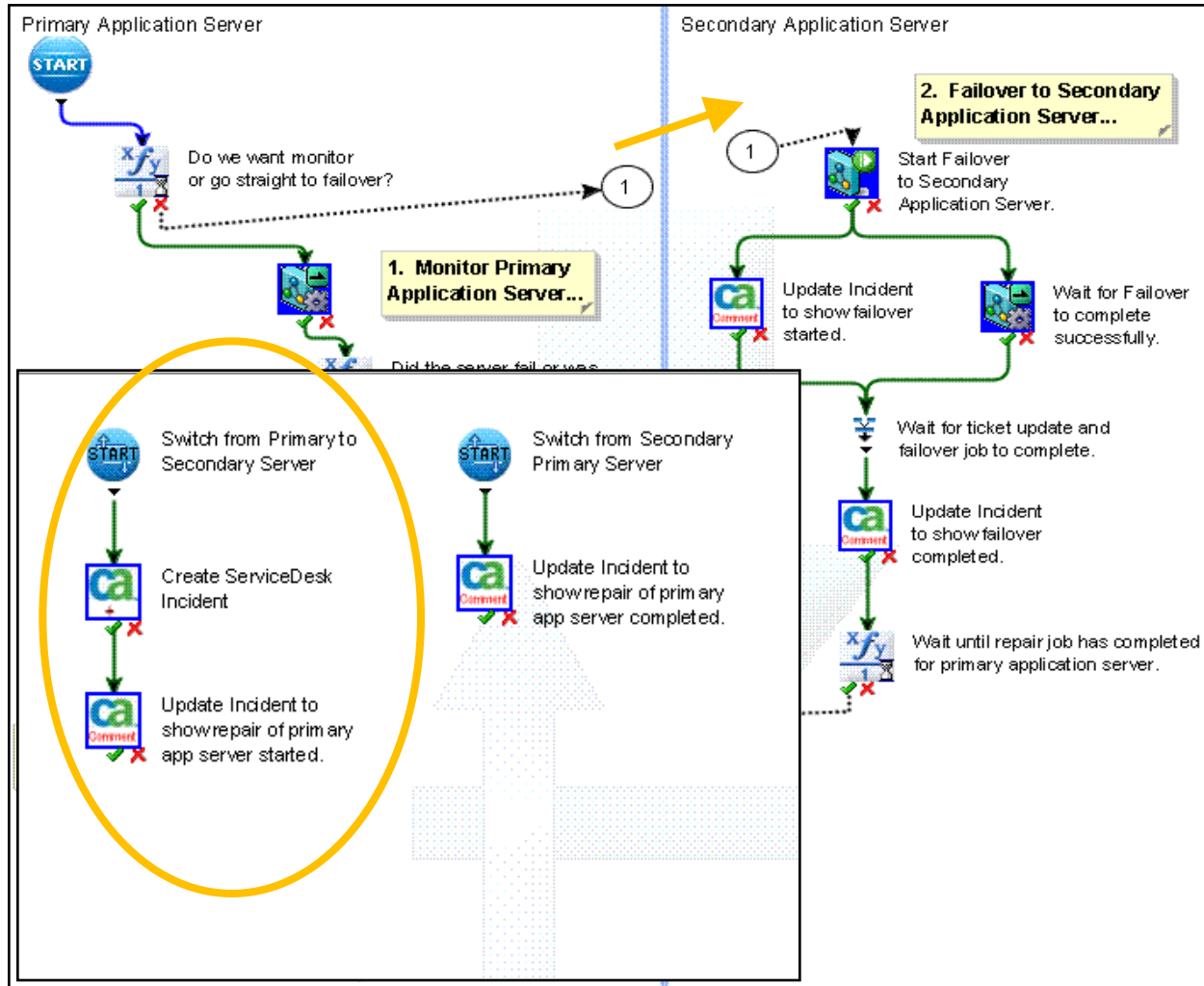

Audit IT PAM

The screenshot displays the IT Process Automation Manager 2.1 interface. The top window shows a process instance 'Handle AppServer Failover' with a tree view of its components. A yellow box highlights the 'ClearedAlarmNoIDOrSpec' component. Below this, a 'Failed' window shows a message: 'Process cleared SPECTRUM alarms' and 'Process to accept cleared alarm from SPECTRUM'. At the bottom, a table titled '.Remedy Gateway/Process SPECTRUM' shows a detailed audit trail of process actions.

Date/Time	User	Action Type	Versions	Description
11/10/08 3:35 PM	Ashish Pokharel	Check-in with new version.	6	The object was successfully checked in with Version 6 .
11/10/08 3:35 PM	Ashish Pokharel	Current version set.	6	Version 6 was successfully made the current version.
11/10/08 3:25 PM	Ashish Pokharel	Checked-out	5	The object was checked out successfully.
11/10/08 3:25 PM	Ashish Pokharel	Started	5	The Process was started at 'Mon Nov 10 15:25:01 EST 2008'.
11/03/08 5:21 PM	Ashish Pokharel	Checked-in	5	The object is checked in successfully with Version 5 .
11/03/08 5:21 PM	Ashish Pokharel	Current version set.	5	Version 5 was successfully made the current version.
11/03/08 5:20 PM	Ashish Pokharel	Checked-out	5	The object was checked out successfully.
11/03/08 4:05 PM	Ashish Pokharel	Checked-in	5	The object is checked-in successfully with Version 5 .
11/03/08 4:05 PM	Ashish Pokharel	Current version set.	5	Version 5 was successfully made the current version.
11/03/08 4:05 PM	Ashish Pokharel	Checked-out	5	The object was checked out successfully.
11/01/08 4:39 PM	Ashish Pokharel	Check-in with new version.	5	The object was successfully checked in with Version 5 .
11/01/08 4:39 PM	Ashish Pokharel	Current version set.	5	Version 5 was successfully made the current version.
11/01/08 4:37 PM	Ashish Pokharel	Checked-out	4	The object was checked out successfully.
11/01/08 2:47 PM	Ashish Pokharel	Check-in with new version.	4	The object was successfully checked in with Version 4 .
11/01/08 2:47 PM	Ashish Pokharel	Current version set.	4	Version 4 was successfully made the current version.
11/01/08 2:47 PM	Ashish Pokharel	Checked-out	3	The object was checked out successfully.
11/01/08 11:40 AM	Anil Parthasarathy	Exported	3	The object has been exported successfully.
11/01/08 11:40 AM	Anil Parthasarathy	Exported	3	The object has been exported successfully.
10/31/08 3:54 PM	Ashish Pokharel	Checked-in	3	The object is checked-in successfully with Version 3 .
10/31/08 3:54 PM	Ashish Pokharel	Current version set.	3	Version 3 was successfully made the current version.

1. ProcessWatch also provides historical audit trail of executed processes.
2. Each instance of a process maintains a log of it's executed operations.
3. Every object in the repository has an audit trail of its creation, modification and deletion.

ServiceDesk, Clarity, Spectrum ...

- Procesy - objekty
 - Request, Incident, Problem Management
 - RFC
 - Configuration Management - CMDB
 - SLM
- GUI
 - WEB Gui
- Rozhrania
 - WEB Services, SQL, command line

Implementácia novej služby

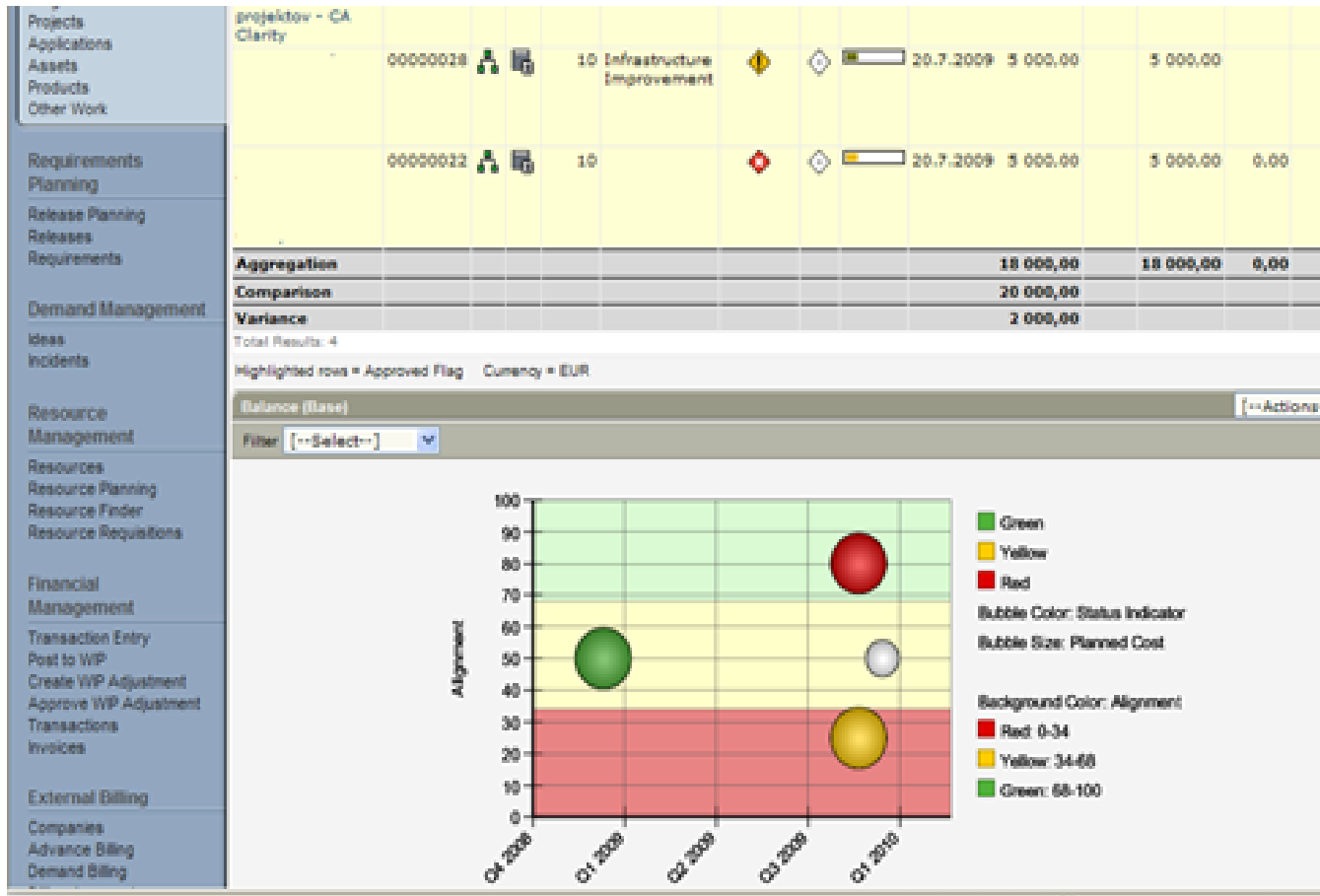

Zastavenie služby

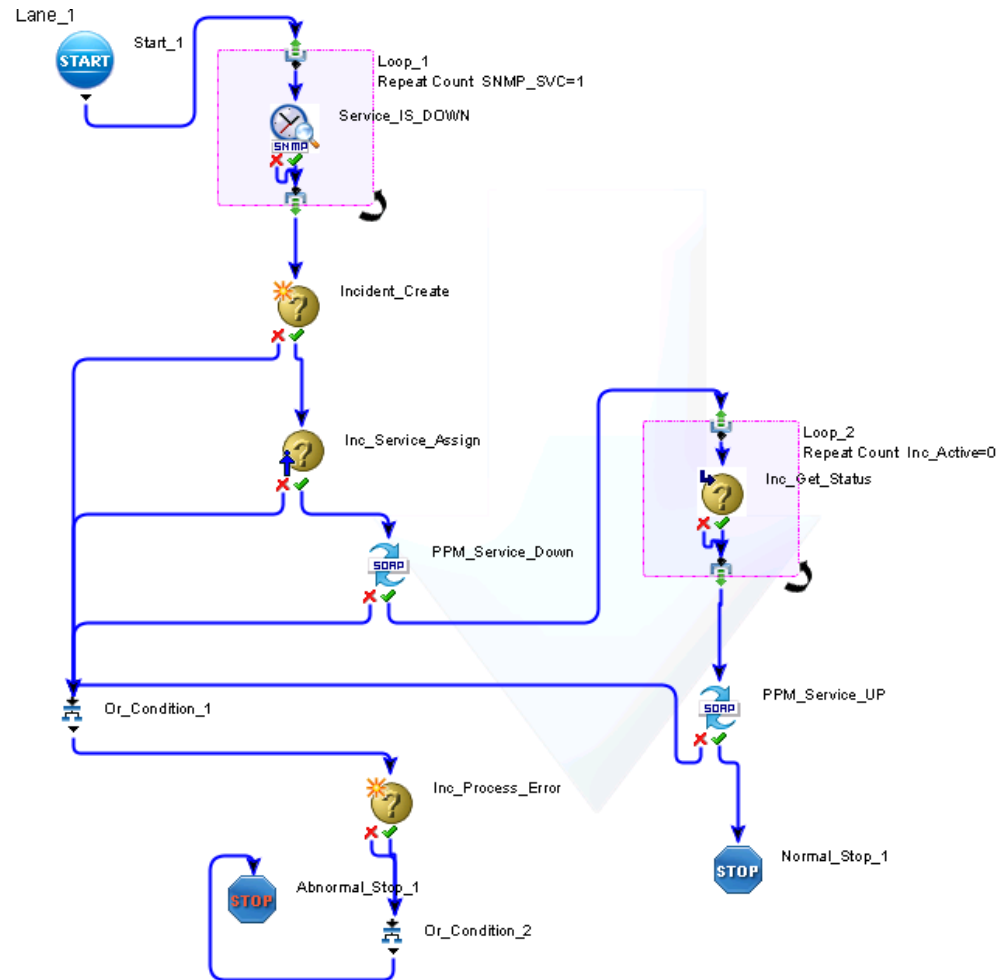

Koniec